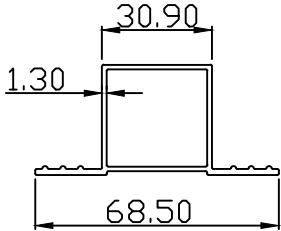
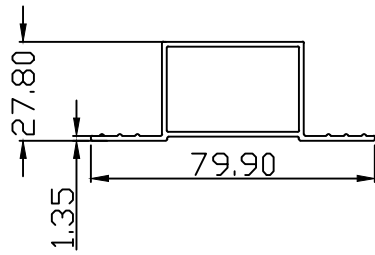
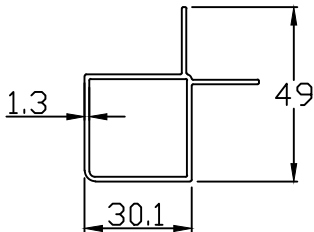
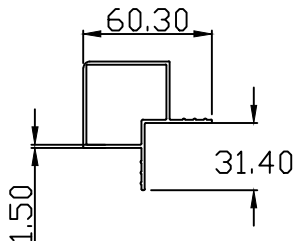
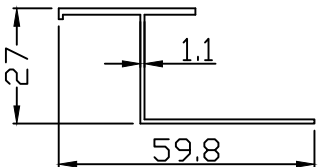
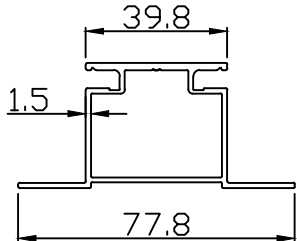
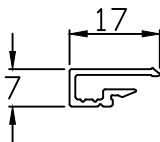
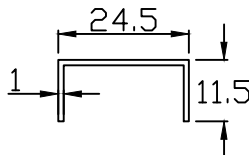
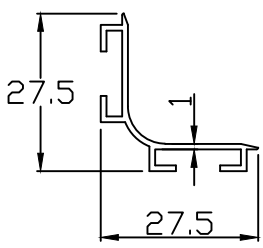
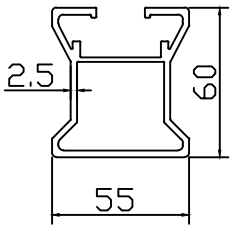
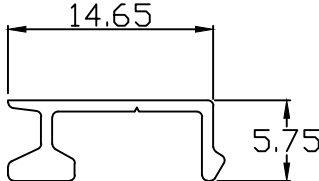
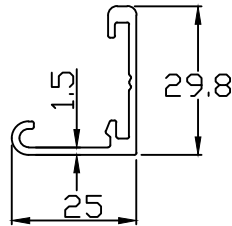
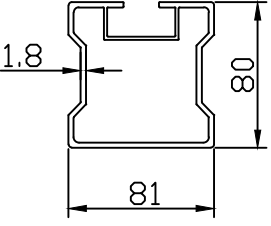
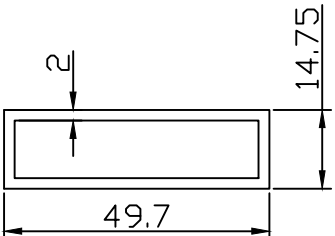
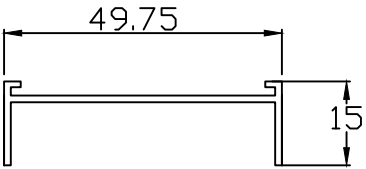
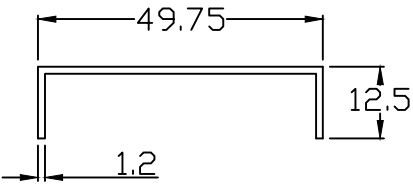

# AIR GRILL PROFILE

<p>SEC NO. :-AHU.- 101R      W.T:- 2.220 kg/12'</p> 	<p>SEC NO. :-AHU.- 102      W.T:- 2.294 kg/12'</p> 
<p>SEC NO. :-AHU.- 103      W.T:- 1.946 kg/12'</p> 	<p>SEC NO. :-AHU.- 104      W.T:- 2.941 kg/12'</p> 
<p>SEC NO. :-AHU.- 105      W.T:- 1.200 kg/12'</p> 	<p>SEC NO. :-AHU.- 106      W.T:- 1.250 kg/12'</p> 
<p>SEC NO. :-AHU.- 107      W.T:- 0.400 kg/12'</p> 	<p>SEC NO. :-AHU.- 108      W.T:- 0.450 kg/12'</p> 

# AIR GRILL PROFILE

<p>SEC NO. :-AHU.- 109                      W.T:- 0.720 kg/12'</p> 	<p>SEC NO. :-AHU.- 110                      W.T:- 6.400 kg/12'</p> 
<p>SEC NO. :-AHU.- 111                      W.T:- 0.270 kg/12'</p> 	<p>SEC NO. :-AHU.- 112                      W.T:- 1.140 kg/12'</p> 
<p>SEC NO. :-AHU.- 113R                      W.T:- 10.717 kg/12'</p> 	<p>SEC NO. :-AHU.- 114                      W.T:- 2.380 kg/12'</p> 
<p>SEC NO. :-AHU.- 115R                      W.T:- 0.764 kg/12'</p> 	<p>SEC NO. :-AHU.- 116                      W.T:- 0.850 kg/12'</p> 

# AIR GRILL PROFILE

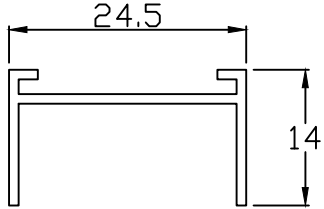
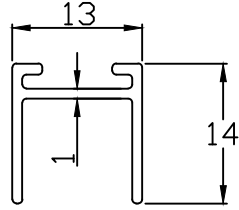
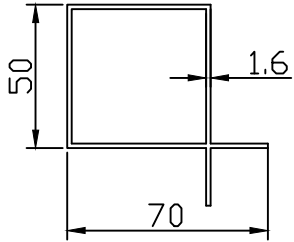
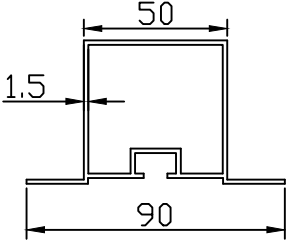
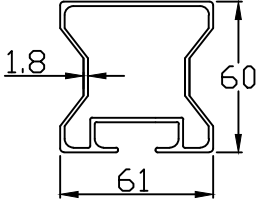
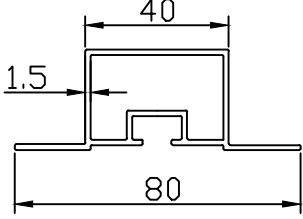
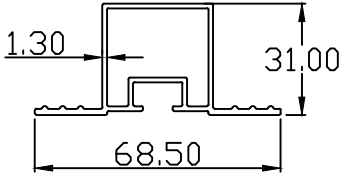
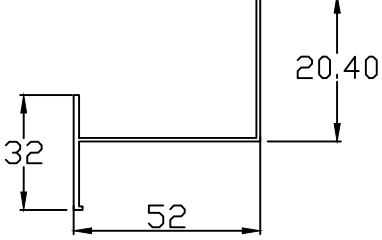
<p>SEC NO. :-AHU.- 117                      W.T:- 0.540 kg/12'</p> 	<p>SEC NO. :-AHU.- 118                      W.T:- 0.850 kg/12'</p> 
<p>SEC NO. :-AHU.- 119                      W.T:- 3.700 kg/12'</p> 	<p>SEC NO. :-AHU.- 120                      W.T:- 4.000 kg/12'</p> 
<p>SEC NO. :-AHU.- 121                      W.T:- 5.064 kg/12'</p> 	<p>SEC NO. :-AHU.- 122                      W.T:- 3.000 kg/12'</p> 
<p>SEC NO. :-AHU.- 123R                      W.T:- 2.485 kg/12'</p> 	<p>SEC NO. :-AHU.- 124                      W.T:- 1.450 kg/12'</p> 

# AIR GRILL PROFILE

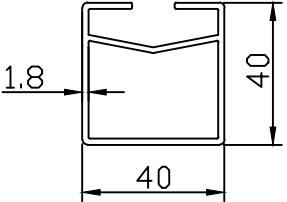
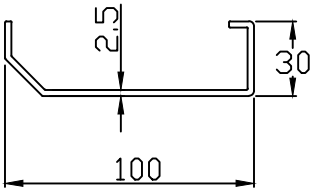
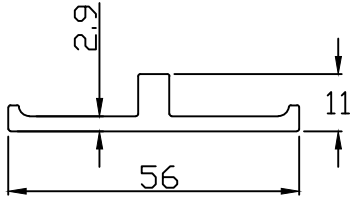
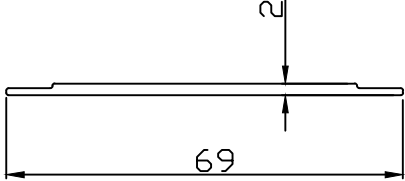
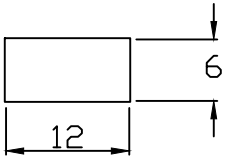
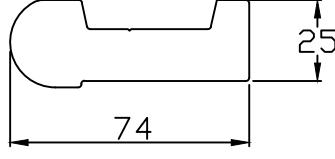
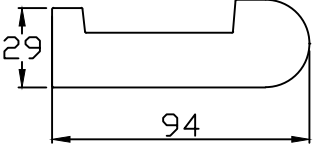
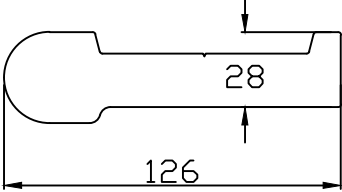
<p>SEC NO. :-AHU.- 125                      W.T:- 3.180 kg/12'</p> 	<p>SEC NO. :-AHU.- 126                      W.T:- 3.800 kg/12'</p> 
<p>SEC NO. :-AHU.- 127                      W.T:- 2.200 kg/12'</p> 	<p>SEC NO. :-AHU.- 128                      W.T:- 1.250 kg/12'</p> 
<p>SEC NO. :-AHU.- 129                      W.T:- 0.700 kg/12'</p> 	<p>SEC NO. :-AHU.- 130                      W.T:- 14.400 kg/12'</p> 
<p>SEC NO. :-AHU.- 131                      W.T:- 21.775 kg/12'</p> 	<p>SEC NO. :-AHU.- 132                      W.T:- 29.430 kg/12'</p> 

# AIR GRILL PROFILE

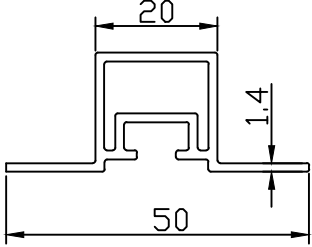
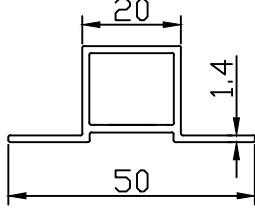
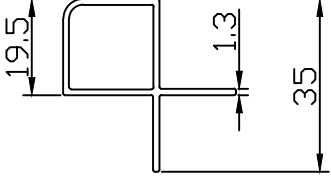
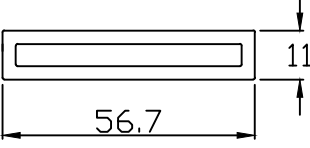
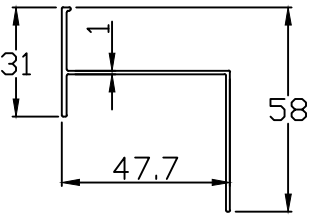
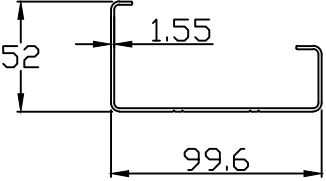
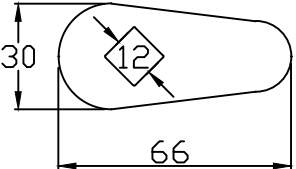
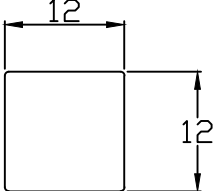
<p>SEC NO. :-AHU.- 135      W.T:- 1.700 kg/12'</p> 	<p>SEC NO. :-AHU.- 136      W.T:- 1.500 kg/12'</p> 
<p>SEC NO. :-AHU.- 137      W.T:- 1.200 kg/12'</p> 	<p>SEC NO. :-AHU.- 138      W.T:- 3.700 kg/12'</p> 
<p>SEC NO. :-AHU.- 139      W.T:- 1.320 kg/12'</p> 	<p>SEC NO. :-AHU.- 140      W.T:- 2.940 kg/12'</p> 
<p>SEC NO. :-AHU.- 141      W.T:- 13.750 kg/12'</p> 	<p>SEC NO. :-AHU.- 142      W.T:- 1.320 kg/12'</p> 

# AIR GRILL PROFILE

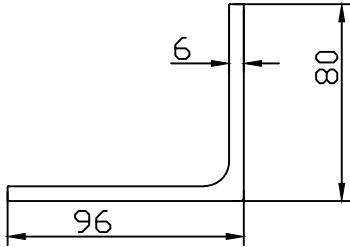
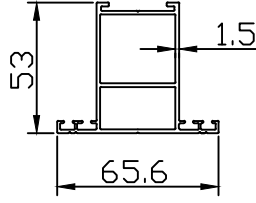
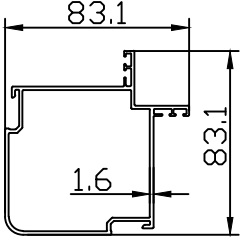
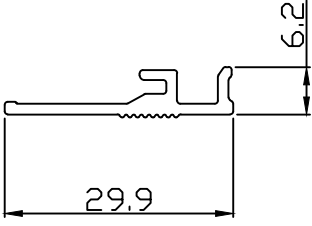
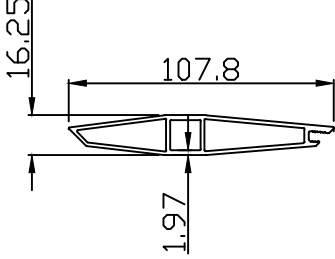
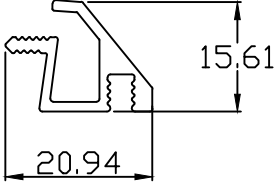
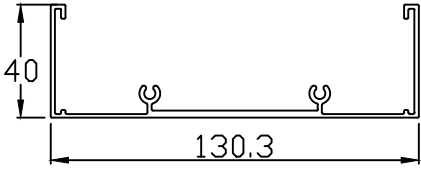
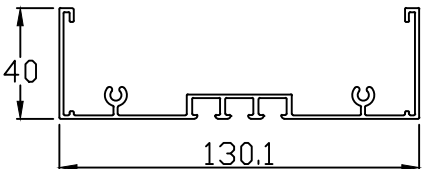
<p>SEC NO. :-AHU.- 143      W.T:- 10.300 kg/12'</p> 	<p>SEC NO. :-AHU.- 144      W.T:- 3.750 kg/12'</p> 
<p>SEC NO. :-AHU.- 145      W.T:- 4.950 kg/12'</p> 	<p>SEC NO. :-AHU.- 146      W.T:- 0.658 kg/12'</p> 
<p>SEC NO. :-AHU.- 147      W.T:- 3.935 kg/12'</p> 	<p>SEC NO. :-AHU.- 148      W.T:- 0.881 kg/12'</p> 
<p>SEC NO. :-AHU.- 149      W.T:- 4.366 kg/12'</p> 	<p>SEC NO. :-AHU.- 150      W.T:- 4.460 kg/12'</p> 

# AIR GRILL PROFILE

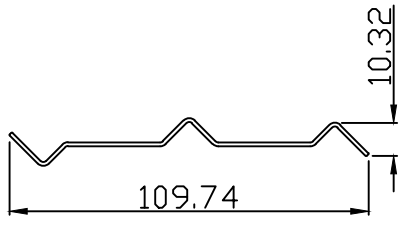
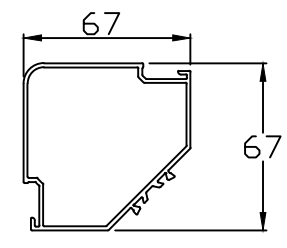
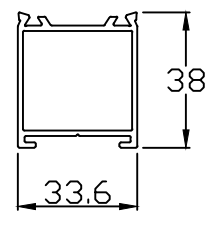
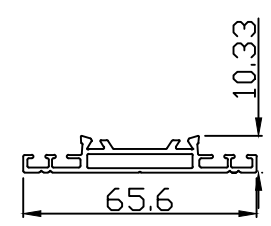
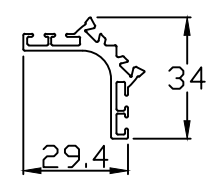
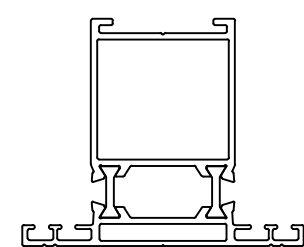
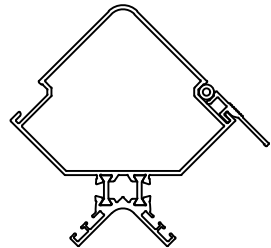
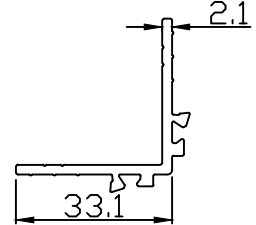
SEC NO. :-AHU.- 151      W.T:- 1.500 kg/12' 	SEC NO. :-AHU.- 152      W.T:- 4.223 kg/12' 
SEC NO. :-AHU.- 153      W.T:- 2.285 kg/12' 	SEC NO. :-AHU.- 154      W.T:- 1.970 kg/12' 
SEC NO. :-AHU.- 155      W.T:- 1.570 kg/12' 	ASSEMBLY 
ASSEMBLY 	SEC NO. :-AHU.- 156      W.T:- 1.635 kg/12' 

# AIR GRILL PROFILE

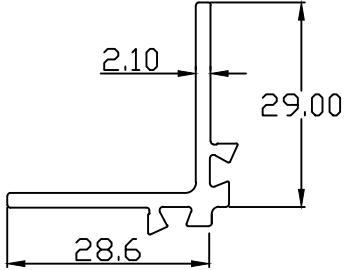
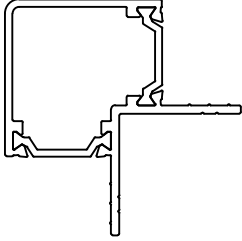
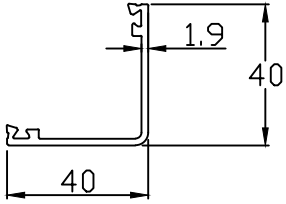
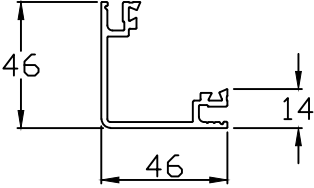
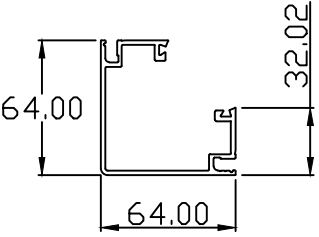
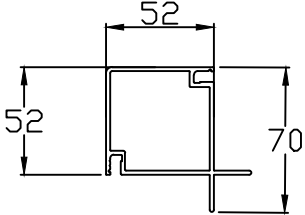
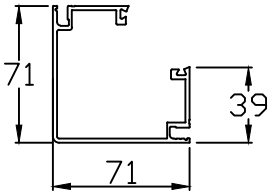
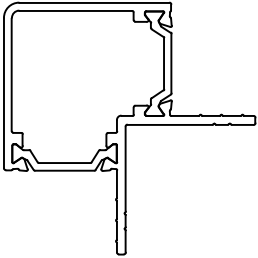
<p>SEC NO. :-AHU.- 156A      W.T:- 1.463 kg/12'</p> 	<p>ASSEMBLY</p> 
<p>SEC NO. :-AHU.- 157      W.T:- 1.770 kg/12'</p> 	<p>SEC NO. :-AHU.- 157A      W.T:- 2.565 kg/12'</p> 
<p>SEC NO. :-AHU.- 157A      W.T:- 4.393 kg/12'</p> 	<p>SEC NO. :-AHU.- 157C      W.T:- 5.030 kg/12'</p> 
<p>SEC NO. :-AHU.- 157D      W.T:- 4.685 kg/12'</p> 	<p>ASSEMBLY</p> 

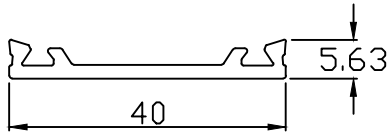
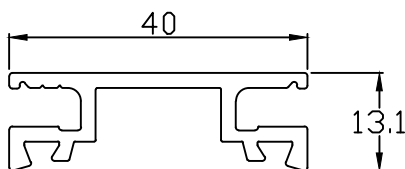
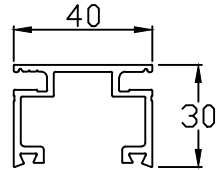
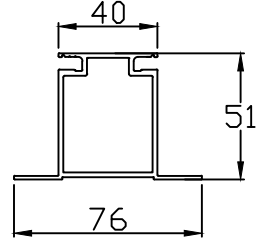
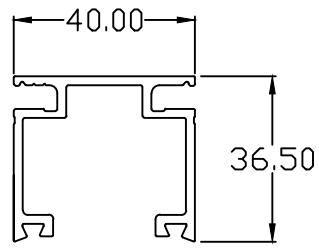
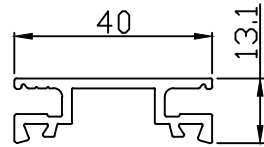
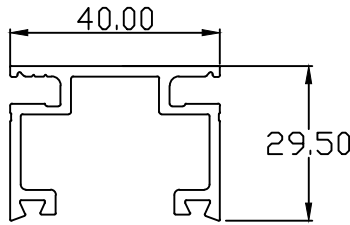
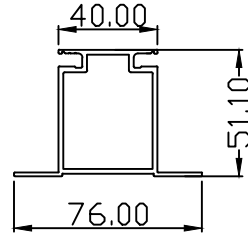

# AIR GRILL PROFILE

<p>SEC NO. :-AHU.- 158                      W.T:- 1.040 kg/12'</p> 	<p>SEC NO. :-AHU.- 158A                      W.T:- 1.700 kg/12'</p> 
<p>SEC NO. :-AHU.- 158B                      W.T:- 2.630 kg/12'</p> 	<p>SEC NO. :-AHU.- 158C                      W.T:- 3.500 kg/12'</p> 
<p>SEC NO. :-AHU.- 158D                      W.T:- 2.900 kg/12'</p> 	<p>SEC NO. :-AHU.- 158A                      W.T:- 1.700 kg/12'</p> 
<p>SEC NO. :-AHU.- 158B                      W.T:- 2.630 kg/12'</p> 	<p>SEC NO. :-AHU.- 158C                      W.T:- 3.500 kg/12'</p> 

# AIR GRILL PROFILE

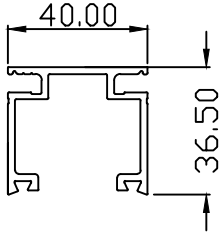
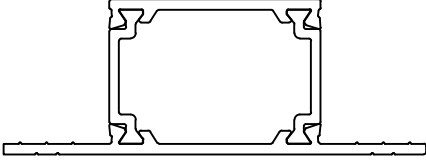
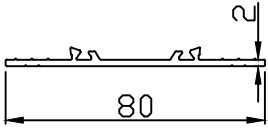
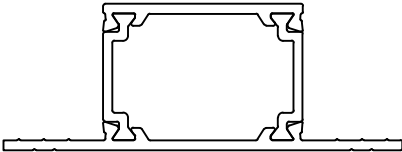
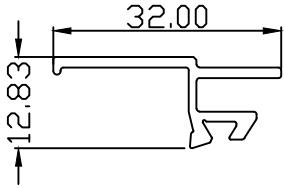
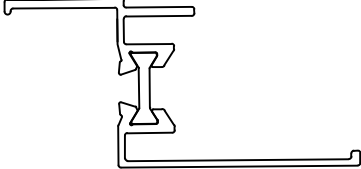
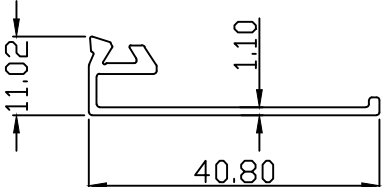
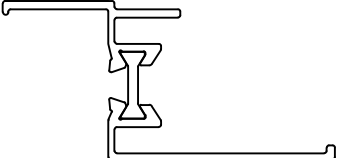
<p>SEC NO. :-AHU.- 158D      W.T:- 2.900 kg/12'</p> 	<p>ASSEMBLY</p> 
<p>SEC NO. :-AHU.- 159      W.T:- 1.850 kg/12'</p> 	<p>ASSEMBLY</p> 
<p>SEC NO. :-AHU.- 160      W.T:- 0.813 kg/12'</p> 	<p>ASSEMBLY</p> 
<p>SEC NO. :-AHU.- 161      W.T:- 0.790 kg/12'</p> 	<p>ASSEMBLY</p> 



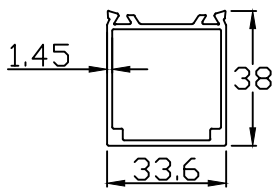
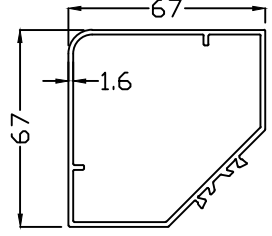
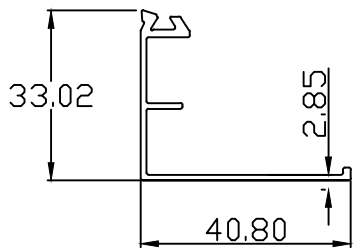
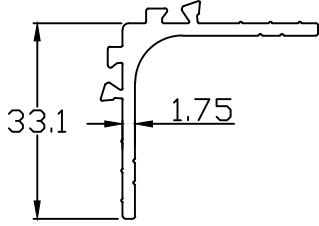
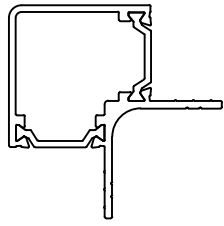
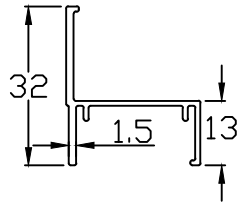
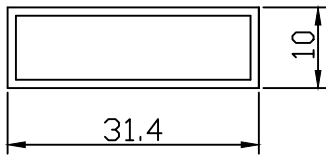
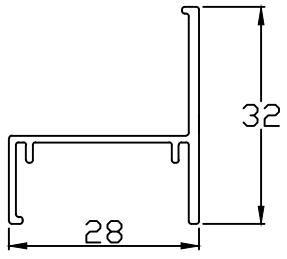

# AIR GRILL PROFILE

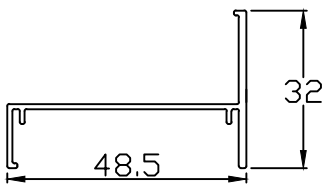
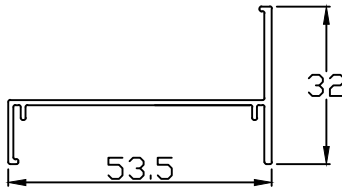
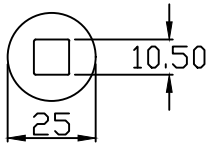
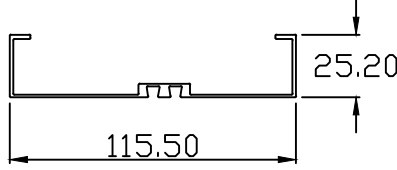
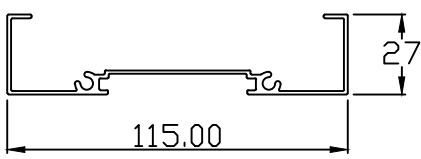
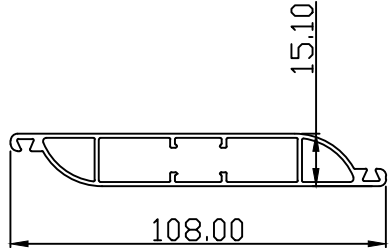
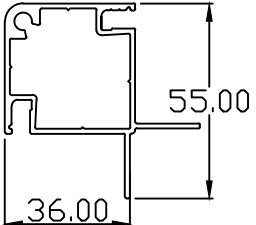
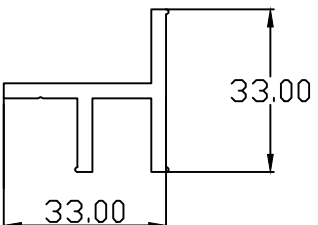
<p>SEC NO. :-AHU.- 162                      W.T:- 2.330 kg/12'</p> 	<p>SEC NO. :-AHU.- 163                      W.T:- 4.200 kg/12'</p> 
<p>SEC NO. :-AHU.- 161A                      W.T:- 0.790 kg/12'</p> 	<p>SEC NO. :-AHU.- 164                      W.T:- 1.770 kg/12'</p> 
<p>ASSEMBLY</p> 	<p>SEC NO. :-AHU.- 165                      W.T:- 0.922 kg/12'</p> 
<p>SEC NO. :-AHU.- 166                      W.T:- 0.817 kg/12'</p> 	<p>SEC NO. :-AHU.- 167                      W.T:- 0.930 kg/12'</p> 

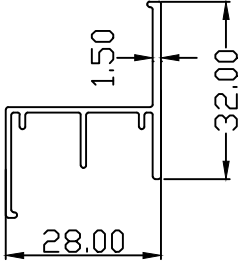
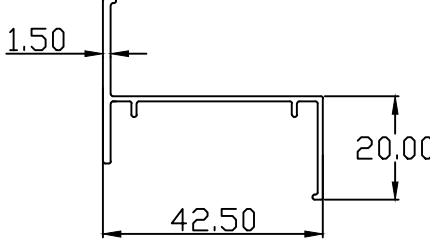
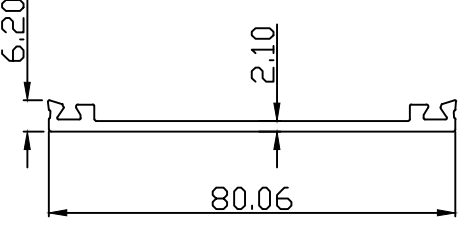

# AIR GRILL PROFILE

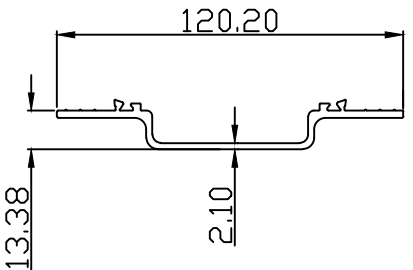
<p>SEC NO. :-AHU.- 168A      W.T:- 1.214 kg/12'</p> 	<p>SEC NO. :-AHU.- 169A      W.T:- 1.184 kg/12'</p> 
<p>SEC NO. :-AHU.- 170      W.T:- 3.850 kg/12'</p> 	<p>SEC NO. :-AHU.- 171      W.T:- 2.650 kg/12'</p> 
<p>SEC NO. :-AHU.- 172      W.T:- 2.700 kg/12'</p> 	<p>SEC NO. :-AHU.- 173      W.T:- 3.350 kg/12'</p> 
<p>SEC NO. :-AHU.- 174      W.T:- 3.200 kg/12'</p> 	<p>SEC NO. :-AHU.- 175      W.T:- 2.320 kg/12'</p> 

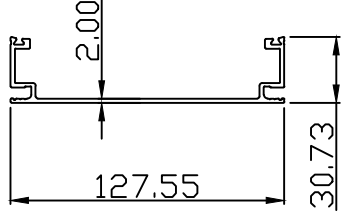
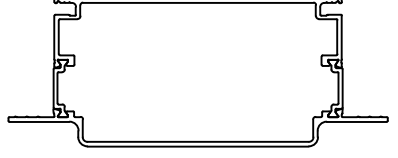
# AIR GRILL PROFILE

SEC NO. :-AHU.- 176      W.T:- 1.100 kg/12'	SEC NO. :-AHU.- 177      W.T:- 1.145 kg/12'
	
SEC NO. :-AHU.- 178      W.T:- 2.043 kg/12'	ASSEMBLY
	
SEC NO. :-AHU.- 179      W.T:- 3.530 kg/12'	ASSEMBLY
	
SEC NO. :-AHU.- 180      W.T:- 4.433 kg/12'	ASSEMBLY
	

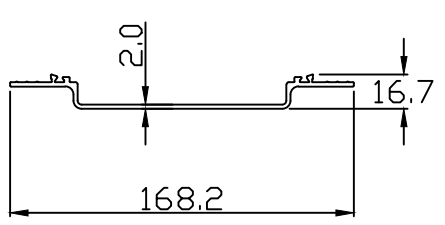
# AIR GRILL PROFILE

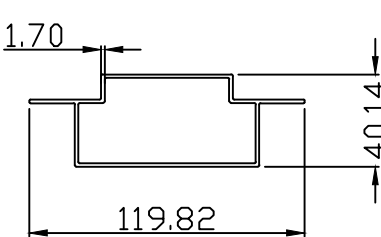
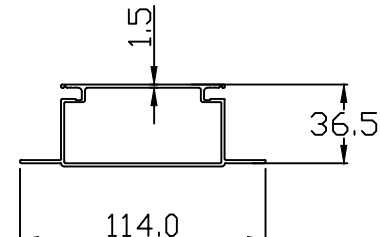
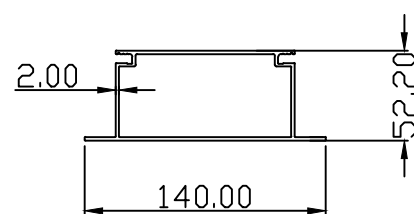
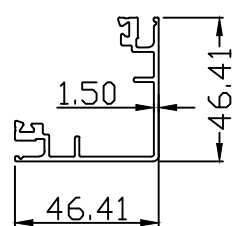
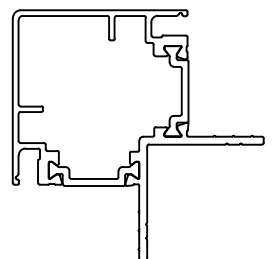
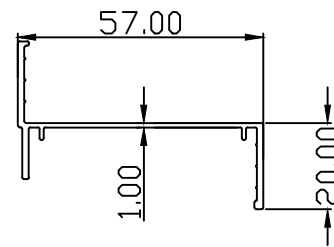
<p>SEC NO. :-AHU.- 181      W.T:- 4.143 kg/12'</p> 	<p>ASSEMBLY</p> 
<p>SEC NO. :-AHU.- 183      W.T:- 4.142 kg/12'</p> 	<p>SEC NO. :-AHU.- 184      W.T:- 4.095 kg/12'</p> 
<p>SEC NO. :-AHU.- 185      W.T:- 7.073 kg/12'</p> 	<p>SEC NO. :-AHU.- 186      W.T:- 2.560 kg/12'</p> 
<p>ASSEMBLY</p> 	<p>SEC NO. :-AHU.- 187      W.T:- 1.388 kg/12'</p> 

# AIR GRILL PROFILE

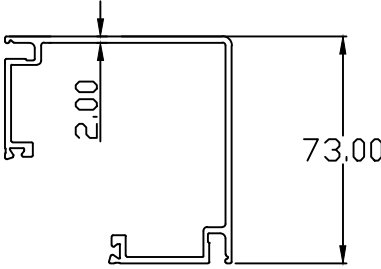
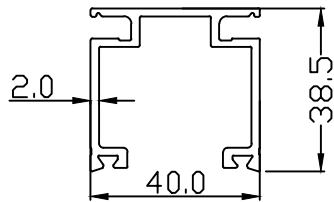
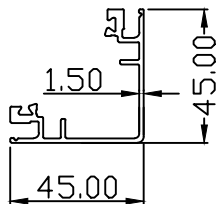
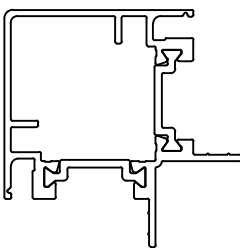
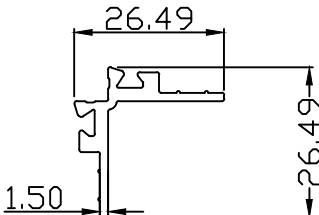
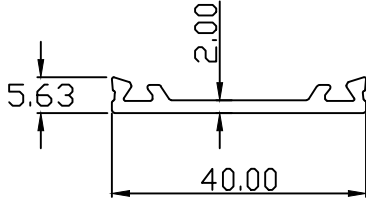
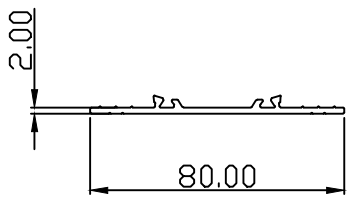
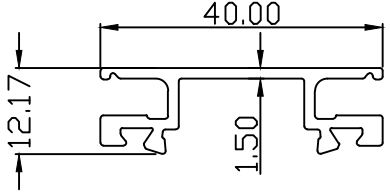
<p>SEC NO. :-AHU.- 188                      W.T:- 5.075 kg/12'</p> 	<p>SEC NO. :-AHU.- 189                      W.T:- 2.962 kg/12'</p> 
<p>SEC NO. :-AHU.- 190                      W.T:- 2.521 kg/12'</p> 	<p>ASSEMBLY</p> 
<p>SEC NO. :-AHU.- 191                      W.T:- 1.100 kg/12'</p> 	<p>SEC NO. :-AHU.- 158T                      W.T:- 1.040 kg/12'</p> 
<p>SEC NO. :-AHU.- 159T                      W.T:- 1.850 kg/12'</p> 	<p>SEC NO. :-AHU.- 194                      W.T:- 1.432kg/12'</p> 

# AIR GRILL PROFILE

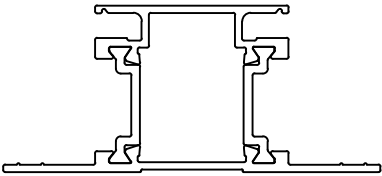
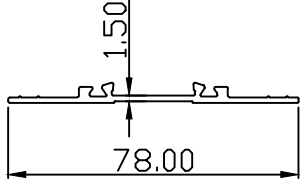
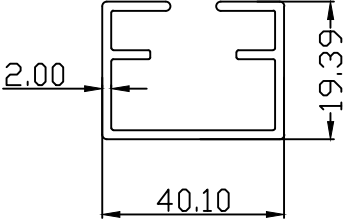
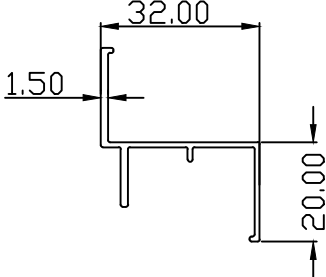
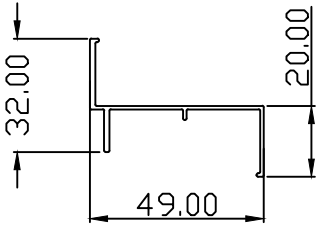
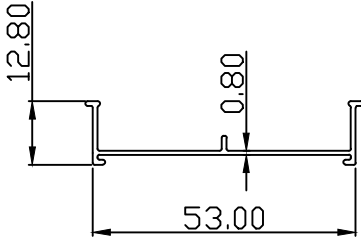
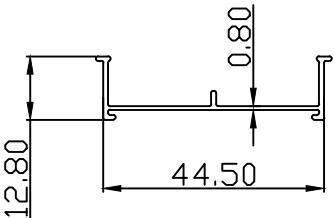
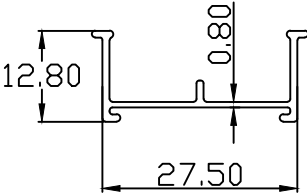
<p>ASSEMBLY</p> 	<p>SEC NO. :-AHU.- 195      W.T:- 1.530 kg/12'</p> 
<p>SEC NO. :-AHU.- 196      W.T:- 2.746 kg/12'</p> 	<p>SEC NO. :-AHU.- 197      W.T:- 1.011 kg/12'</p> 
<p>SEC NO. :-AHU.- 198      W.T:- 1.180 kg/12'</p> 	<p>SEC NO. :-AHU.- 199      W.T:- 0.749 kg/12'</p> 
<p>SEC NO. :-AHU.- 158T      W.T:- 1.040 kg/12'</p> 	<p>SEC NO. :-AHU.- 201      W.T:- 0.547 kg/12'</p> 

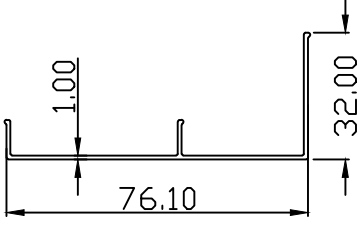
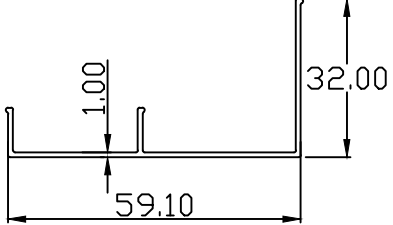
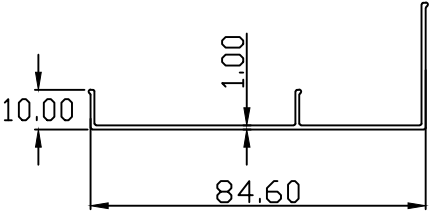
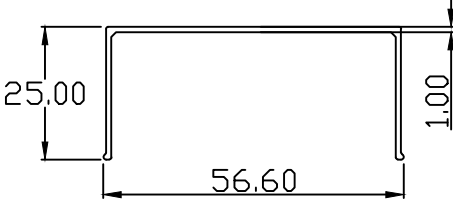
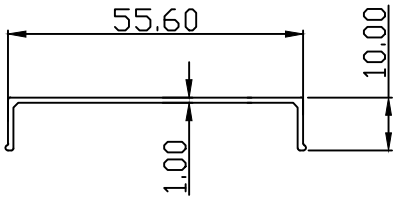
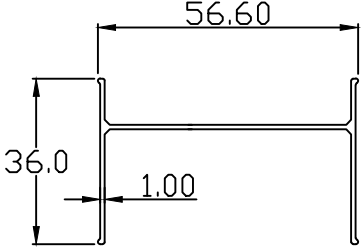
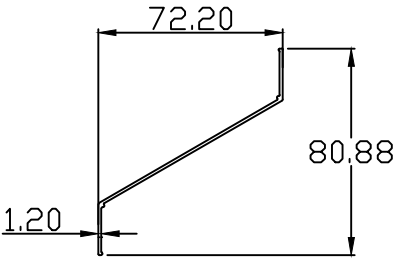
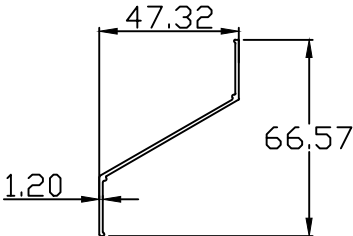

# AIR GRILL PROFILE

<p>SEC NO. :-AHU.- 202                      W.T:- 1.246 kg/12'</p> 	<p>SEC NO. :-AHU.- 203                      W.T:- 1.078 kg/12'</p> 
<p>SEC NO. :-AHU.- 204                      W.T:- 1.330 kg/12'</p> 	<p>SEC NO. :-AHU.- 205                      W.T:- 1.038 kg/12'</p> 
<p>SEC NO. :-AHU.- 206                      W.T:- 0.741 kg/12'</p> 	<p>SEC NO. :-AHU.- 207                      W.T:- 1.279 kg/12'</p> 
<p>SEC NO. :-AHU.- 208                      W.T:- 1.483 kg/12'</p> 	<p>SEC NO. :-AHU.- 209                      W.T:- 1.140 kg/12'</p> 

# AIR GRILL PROFILE

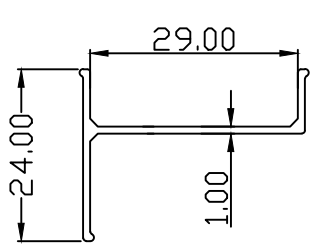
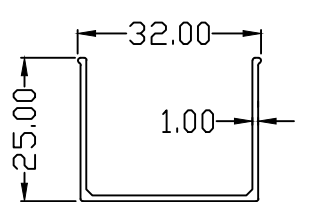
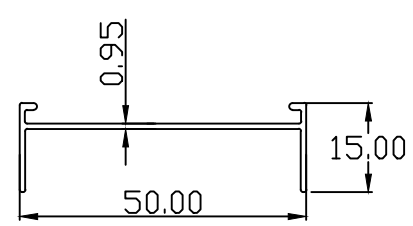
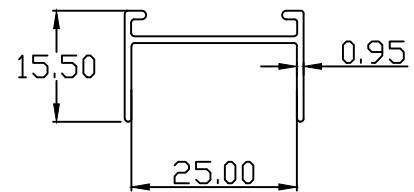
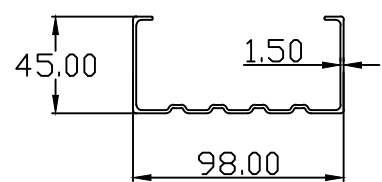
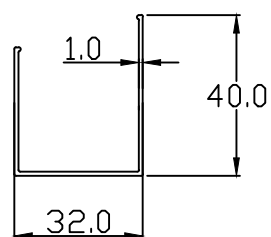
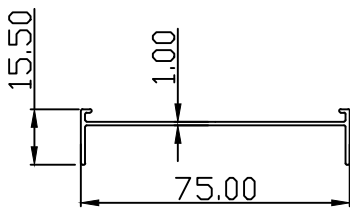
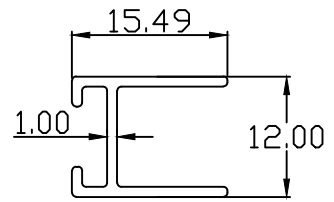
<p>SEC NO. :-AHU.- 210      W.T:- 0.640 kg/12'</p> 	<p>SEC NO. :-AHU.- 211      W.T:- 0.798 kg/12'</p> 
<p>SEC NO. :-AHU.- 212      W.T:- 0.785 kg/12'</p> 	<p>SEC NO. :-AHU.- 213      W.T:- 0.551 kg/12'</p> 
<p>SEC NO. :-AHU.- 214      W.T:- 3.124 kg/12'</p> 	<p>SEC NO. :-AHU.- 215      W.T:- 1.015 kg/12'</p> 
<p>SEC NO. :-AHU.- 216      W.T:- 1.105 kg/12'</p> 	<p>SEC NO. :-AHU.- 217      W.T:- 0.443 kg/12'</p> 

# AIR GRILL PROFILE

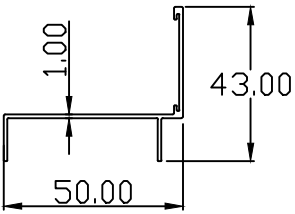
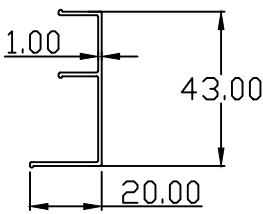
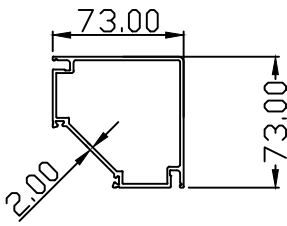
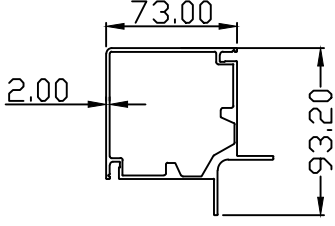
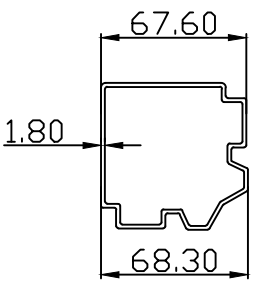
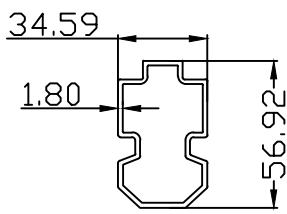
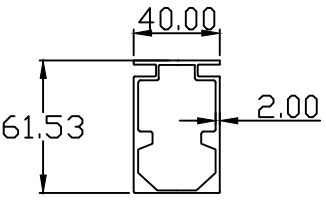
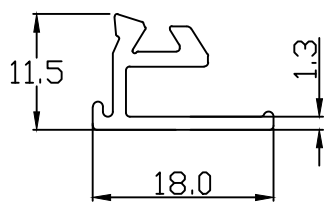
<p>SEC NO. :-AHU.- 218                      W.T:- 1.095 kg/12'</p> 	<p>SEC NO. :-AHU.- 219                      W.T:- 0.842 kg/12'</p> 
<p>SEC NO. :-AHU.- 220                      W.T:- 5.803 kg/12'</p> 	<p>SEC NO. :-AHU.- 221                      W.T:- 8.353 kg/12'</p> 
<p>SEC NO. :-AHU.- 222                      W.T:- 4.942 kg/12'</p> 	<p>SEC NO. :-AHU.- 223                      W.T:- 3.397 kg/12'</p> 
<p>SEC NO. :-AHU.- 224                      W.T:- 5.456 kg/12'</p> 	<p>SEC NO. :-AHU.- 225                      W.T:- 0.589 kg/12'</p> 

# AIR GRILL PROFILE

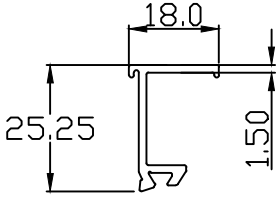
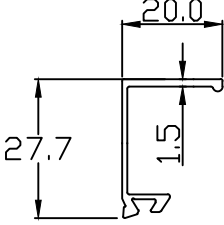
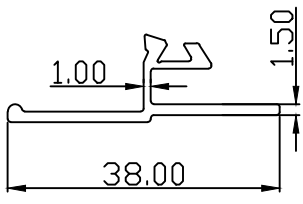
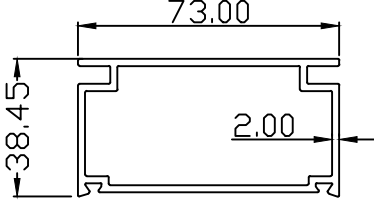
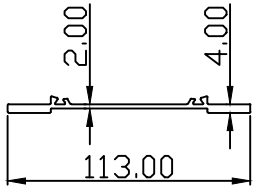
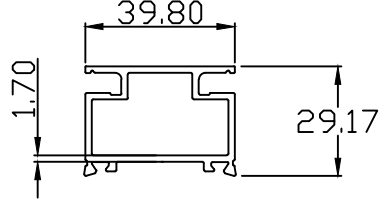
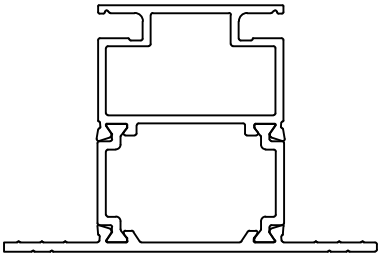
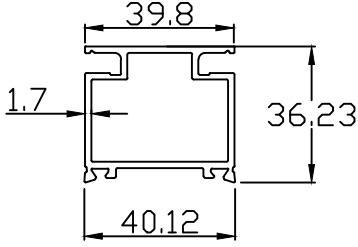
<p>SEC NO. :-AHU.- 226                      W.T:- 0.829 kg/12'</p> 	<p>SEC NO. :-AHU.- 227                      W.T:- 0.752 kg/12'</p> 
<p>SEC NO. :-AHU.- 228                      W.T:- 0.866 kg/12'</p> 	<p>SEC NO. :-AHU.- 299                      W.T:- 1.298 kg/12'</p> 
<p>SEC NO. :-AHU.- 230                      W.T:- 0.905 kg/12'</p> 	<p>SEC NO. :-AHU.- 158BT                      W.T:- 2.660 kg/12'</p> 
<p>ASSEMBLY</p> 	<p>SEC NO. :-AHU.- 158BT                      W.T:- 2.660 kg/12'</p> 

# AIR GRILL PROFILE

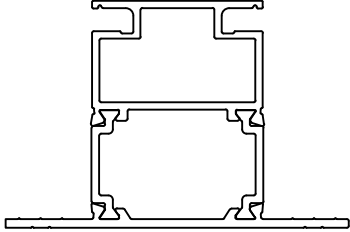
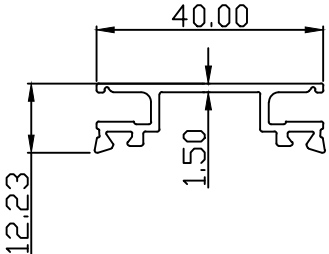
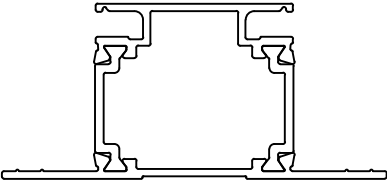
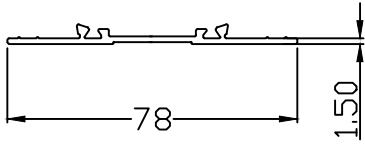
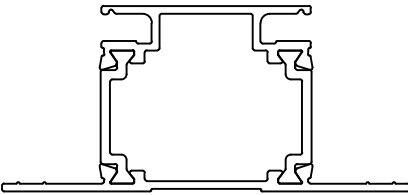
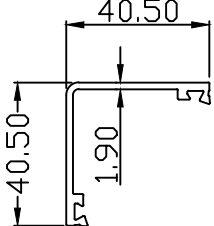
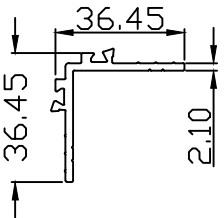
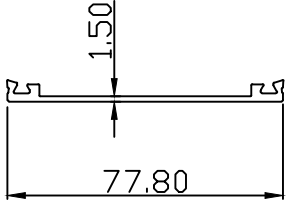
<p>ASSEMBLY</p> 	<p>SEC NO. :-AHU.- 194T      W.T:- 1.432 kg/12'</p> 
<p>ASSEMBLY</p> 	<p>SEC NO. :-AHU.- 195T      W.T:- 1.530 kg/12'</p> 
<p>ASSEMBLY</p> 	<p>SEC NO. :-AHU.- 231      W.T:- 0.502 kg/12'</p> 
<p>SEC NO. :-AHU.- 232      W.T:- 0.466 kg/mtr</p> 	<p>SEC NO. :-AHU.- 233      W.T:- 0.436 kg/mtr</p> 

# AIR GRILL PROFILE

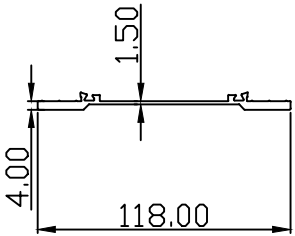
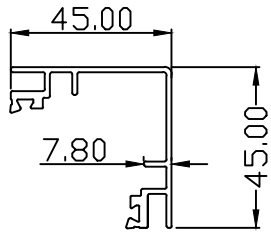
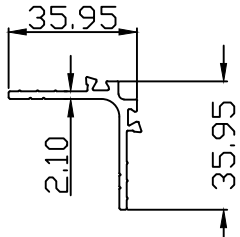
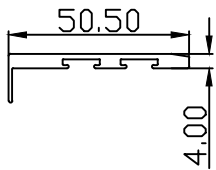
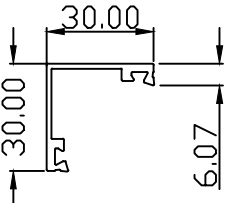
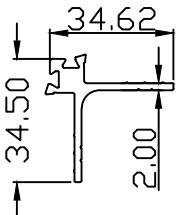
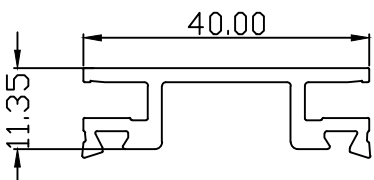
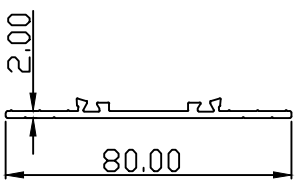
<p>SEC NO. :-AHU.- 227      W.T:- 0.881 kg/mtr</p> 	<p>SEC NO. :-AHU.- 235      W.T:- 0.649 kg/mtr</p> 
<p>SEC NO. :-AHU.- 226      W.T:- 0.462 kg/mtr</p> 	<p>SEC NO. :-AHU.- 237      W.T:- 0.766 kg/mtr</p> 
<p>SEC NO. :-AHU.- 238      W.T:- 0.347 kg/mtr</p> 	<p>SEC NO. :-AHU.- 239      W.T:- 0.492 kg/mtr</p> 
<p>SEC NO. :-AHU.- 240      W.T:- 0.482 kg/mtr</p> 	<p>SEC NO. :-AHU.- 241      W.T:- 0.504 kg/mtr</p> 

# AIR GRILL PROFILE

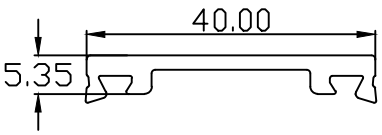
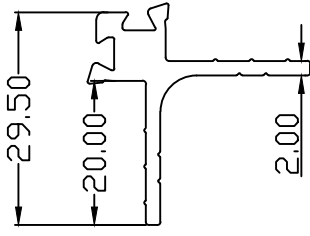
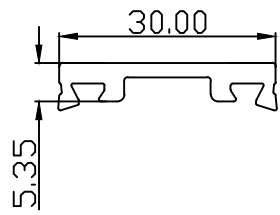
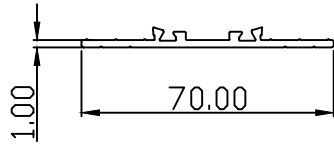
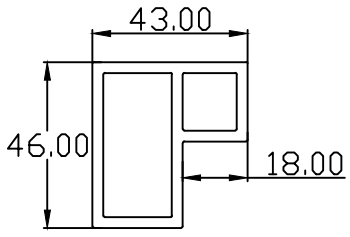
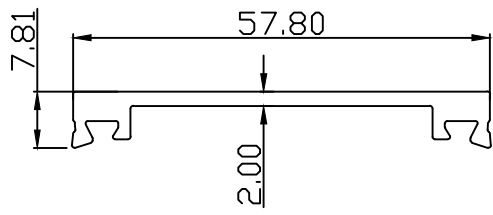
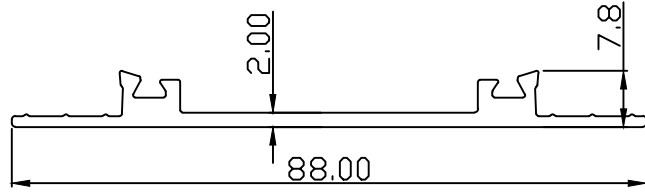
<p>SEC NO. :-AHU.- 242 <span style="float: right;">W.T:- 0.337 kg/mtr</span></p> 	<p>SEC NO. :-AHU.- 243 <span style="float: right;">W.T:- 0.438 kg/mtr</span></p> 
<p>SEC NO. :-AHU.- 244 <span style="float: right;">W.T:- 0.283 kg/mtr</span></p> 	<p>SEC NO. :-AHU.- 245 <span style="float: right;">W.T:- 0.450 kg/mtr</span></p> 
<p>SEC NO. :-AHU.- 246 <span style="float: right;">W.T:- 1.474 kg/mtr</span></p> 	<p>SEC NO. :-AHU.- 247 <span style="float: right;">W.T:- 0.469 kg/mtr</span></p> 
<p>SEC NO. :-AHU.- 248 <span style="float: right;">W.T:- 0.596 kg/mtr</span></p> 	

# AIR GRILL PROFILE

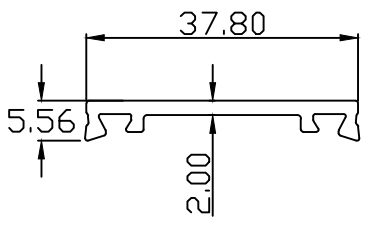
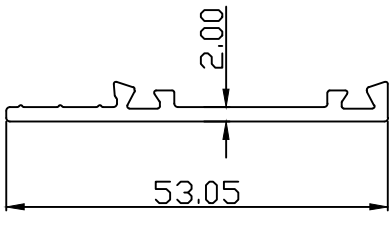
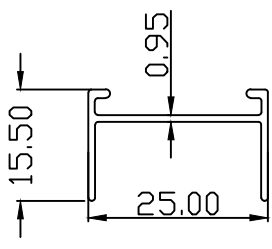
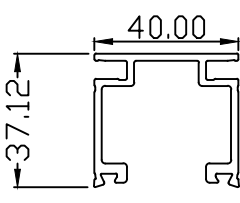
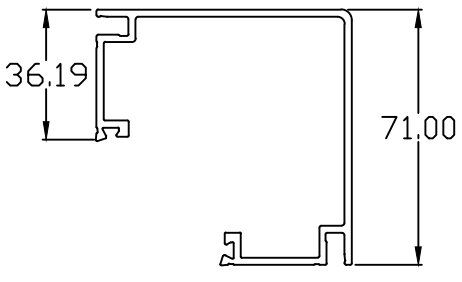
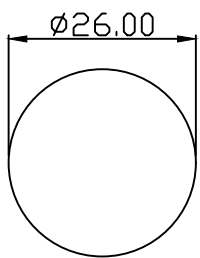
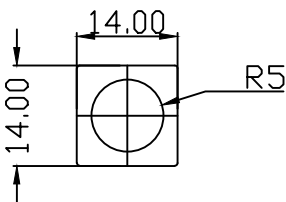
<p>SEC NO. :-AHU.- 249      W.T:- 0.264 kg/mtr</p> 	<p>SEC NO. :-AHU.- 250      W.T:- 0.352 kg/mtr</p> 
<p>SEC NO. :-AHU.- 251      W.T:- 0.551 kg/mtr</p> 	<p>SEC NO. :-AHU.- 252      W.T:- 0.833 kg/mtr</p> 
<p>SEC NO. :-AHU.- 253      W.T:- 1.331 kg/mtr</p> 	
<p>SEC NO. :-AHU.- 254      W.T:- 1.433 kg/mtr</p> 	<p>SEC NO. :-AHU.- 255      W.T:- 0.316 kg/mtr</p> 



# AIR GRILL PROFILE

SEC NO. :-AHU.- 256 <span style="float: right;">W.T:- 1.470 kg/mtr</span>	
SEC NO. :-AHU.- 258 <span style="float: right;">W.T:- 0.682 kg/mtr</span>	SEC NO. :-AHU.- 257 <span style="float: right;">W.T:- 0.830 kg/mtr</span>
SEC NO. :-AHU.- 259 <span style="float: right;">W.T:- 0.984 kg/mtr</span>	SEC NO. :-AHU.- 260 <span style="float: right;">W.T:- 1.470 kg/mtr</span>
SEC NO. :-AHU.- 261 <span style="float: right;">W.T:- 0.420 kg/mtr</span>	SEC NO. :-AHU.- 262 <span style="float: right;">W.T:- 0.646 kg/mtr</span>

# AIR GRILL PROFILE

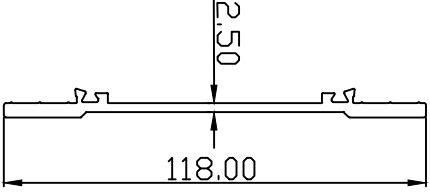
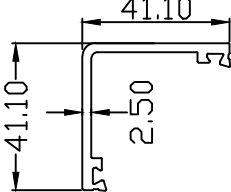
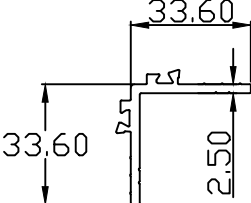
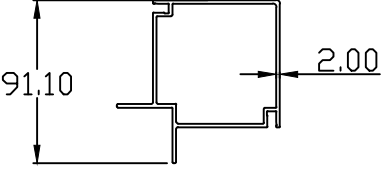
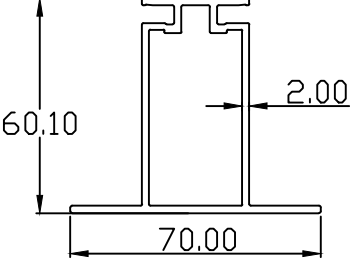
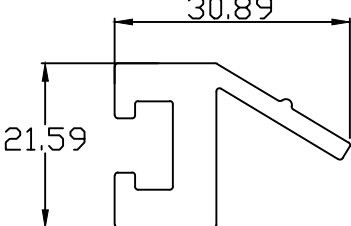
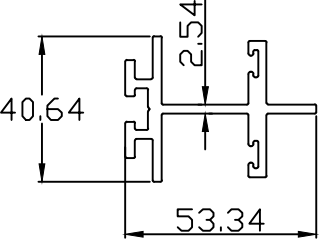
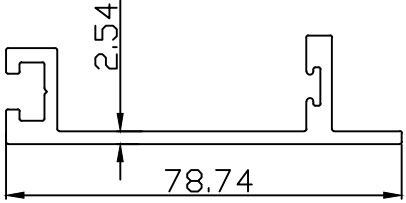
<p>SEC NO. :-AHU.- 263      W.T:- 1.073 kg/mtr</p> 	<p>SEC NO. :-AHU.- 264      W.T:- 1.470 kg/mtr</p> 
<p>SEC NO. :-AHU.- 265      W.T:- 0.534 kg/mtr</p> 	<p>SEC NO. :-AHU.- 266      W.T:- 1.816 kg/mtr</p> 
<p>SEC NO. :-AHU.- 267      W.T:- 1.271 kg/mtr</p> 	<p>SEC NO. :-AHU.- 268      W.T:- 0.709 kg/mtr</p> 
<p>SEC NO. :-AHU.- 269      W.T:- 1.222 kg/mtr</p> 	<p>SEC NO. :-AHU.- 270      W.T:- 0.999 kg/mtr</p> 

# AIR GRILL PROFILE

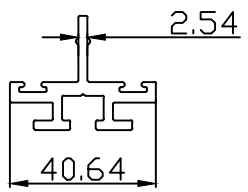
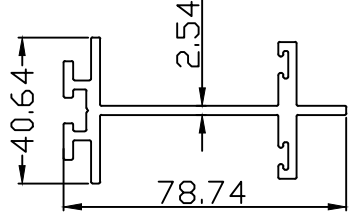
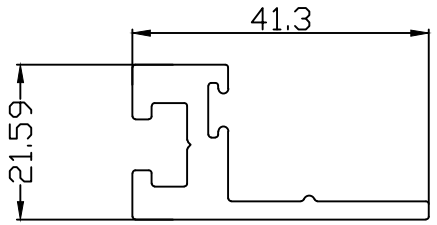
<p>SEC NO. :-AHU.- 271      W.T:- 0.818 kg/mtr</p> 	<p>SEC NO. :-AHU.- 272      W.T:- 1.396 kg/mtr</p> 
<p>SEC NO. :-AHU.- 273      W.T:- 0.717 kg/mtr</p> 	<p>SEC NO. :-AHU.- 274      W.T:- 0.825 kg/mtr</p> 