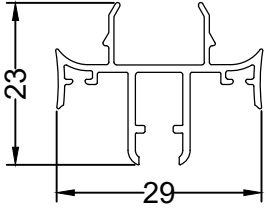
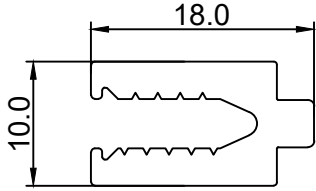
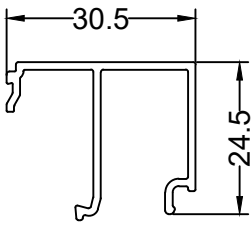
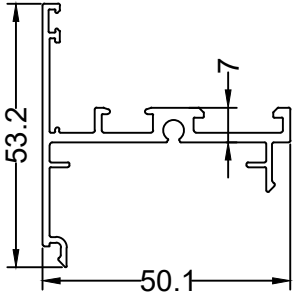
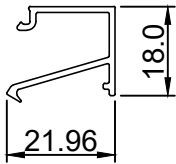
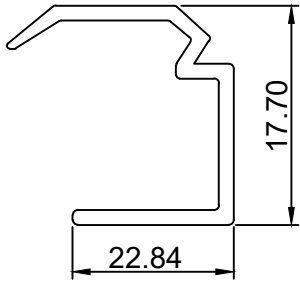
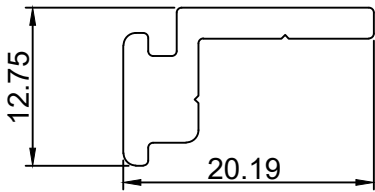
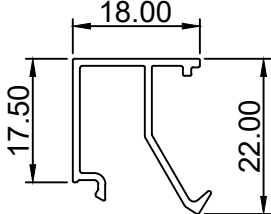
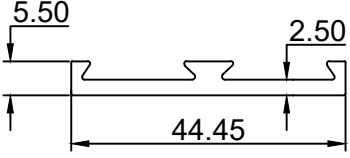
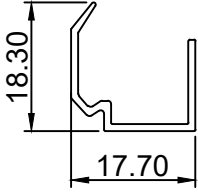
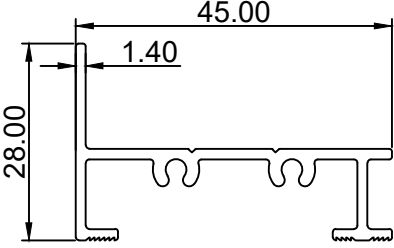
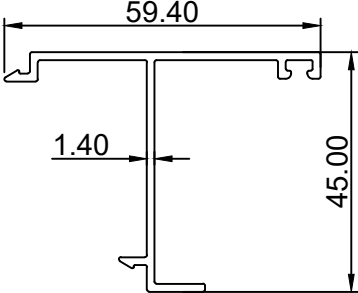
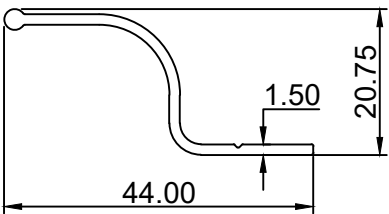
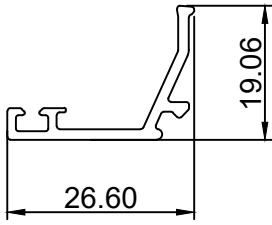
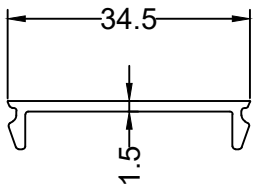
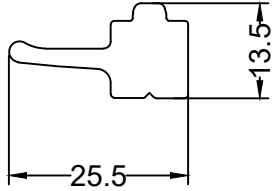

GLAZINGS

<p>SEC NO. :-AA-1001 W.T:- 1.185 kg/12'</p> 	<p>SEC NO. :-AA-1002 W.T:- 1.080kg/12'</p> 
<p>SEC NO. :-AA-1006 W.T:- 1.090 kg/12'</p> 	<p>SEC NO. :-AA-1005 W.T:- 2.490 kg/12'</p> 
<p>SEC NO. :-EF-114 W.T:- 0.767 kg/12'</p> 	<p>SEC NO. :-EI-01 W.T:- 0.554 kg/12'</p> 
<p>SEC NO. :-EF-104 W.T:- 0.900 kg/12'</p> 	<p>SEC NO. :-JP-46 W.T:- 0.680 kg/12'</p> 

GLAZINGS

<p>SEC NO. :-JP-67 W.T:- 1.420 kg/12'</p> 	<p>SEC NO. :-JP-47 W.T:- 0.470 kg/12'</p> 
<p>SEC NO. :-AA-1007 W.T:- 1.640 kg/12'</p> 	<p>SEC NO. :-AA-1008 W.T:- 1.890 kg/12'</p> 
<p>SEC NO. :-AA-1009 W.T:- 0.860 kg/12'</p> 	<p>SEC NO. :-AA-1010 W.T:- 0.760 kg/12'</p> 
<p>SEC NO. :-AA-1011 W.T:- 0.680 kg/12'</p> 	<p>SEC NO. :-AA-1012 W.T:- 1.690 kg/12'</p> 

GLAZINGS

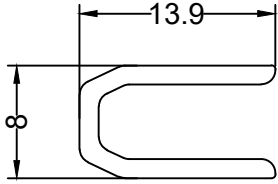
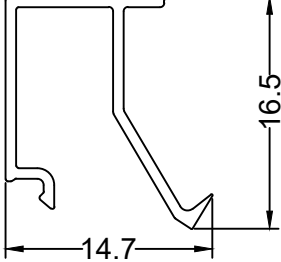
<p>SEC NO. :-AA-1013 W.T:- 0.410 kg/12'</p> 	<p>SEC NO. :-AA-008 W.T:- 0.620 kg/12'</p> 
--	--