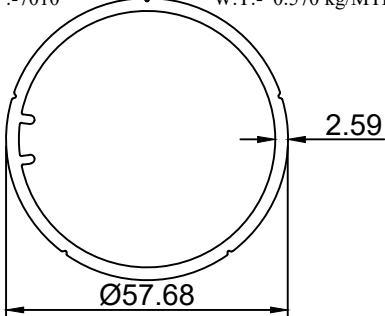
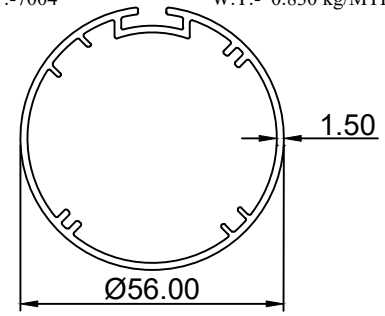
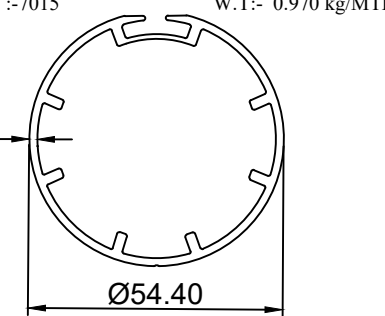
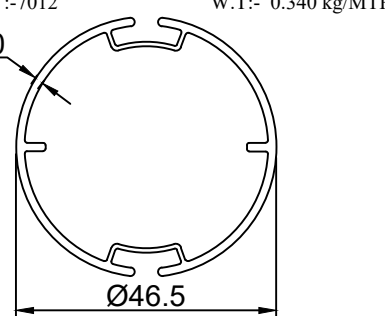
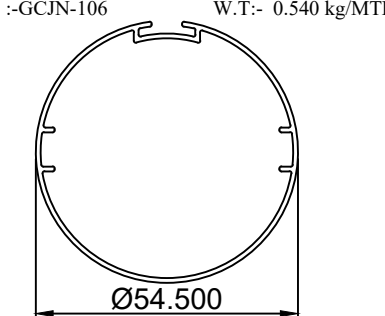
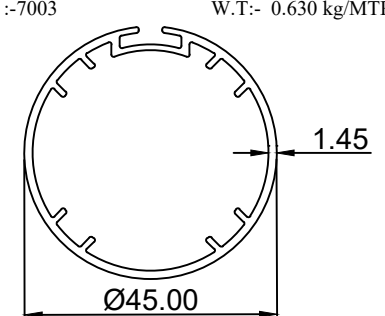
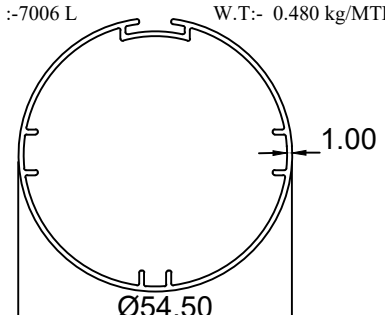
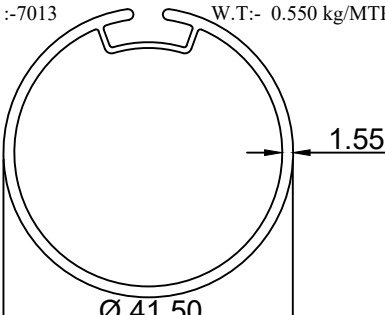
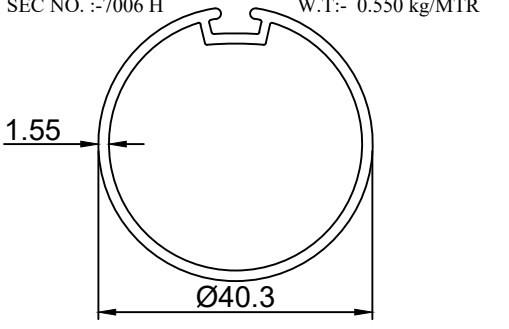
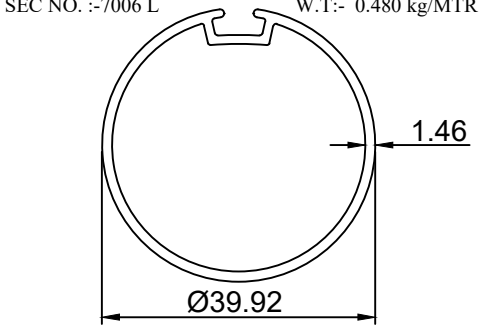
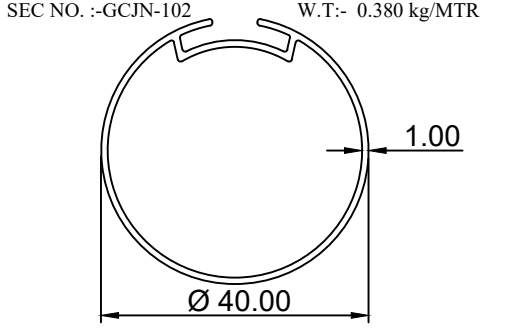
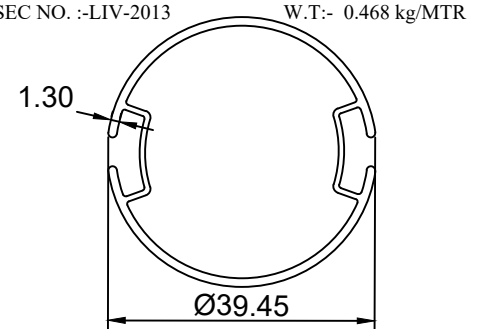
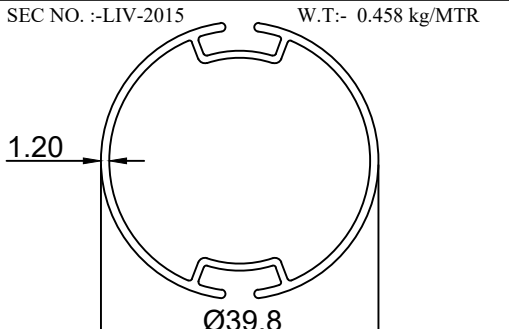
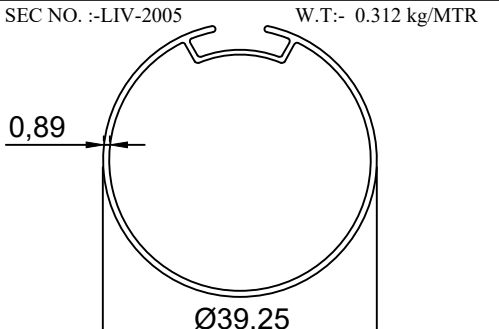
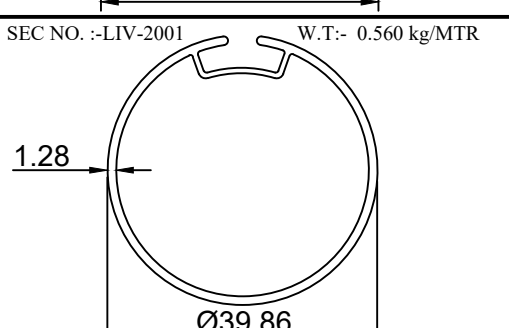
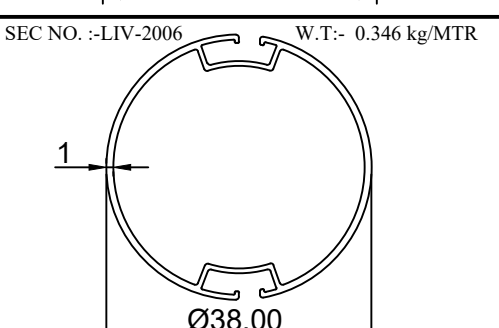

# VENETIAN BLINDS

<p>SEC NO. :-7010 W.T:- 0.570 kg/MTR</p>  <p>Ø57.68</p> <p>2.59</p>	<p>SEC NO. :-7004 W.T:- 0.830 kg/MTR</p>  <p>Ø56.00</p> <p>1.50</p>
<p>SEC NO. :-7015 W.T:- 0.970 kg/MTR</p>  <p>Ø54.40</p> <p>1.70</p>	<p>SEC NO. :-7012 W.T:- 0.340 kg/MTR</p>  <p>Ø46.5</p> <p>1.50</p>
<p>SEC NO. :-GCJN-106 W.T:- 0.540 kg/MTR</p>  <p>Ø54.500</p>	<p>SEC NO. :-7003 W.T:- 0.630 kg/MTR</p>  <p>Ø45.00</p> <p>1.45</p>
<p>SEC NO. :-7006 L W.T:- 0.480 kg/MTR</p>  <p>Ø54.50</p> <p>1.00</p>	<p>SEC NO. :-7013 W.T:- 0.550 kg/MTR</p>  <p>Ø 41.50</p> <p>1.55</p>

# VENETIAN BLINDS

<p>SEC NO. :-7006 H      W.T:- 0.550 kg/MTR</p>  <p style="text-align: center;">Ø40.3</p>	<p>SEC NO. :-7006 L      W.T:- 0.480 kg/MTR</p>  <p style="text-align: center;">Ø39.92</p>
<p>SEC NO. :-GCJN-102      W.T:- 0.380 kg/MTR</p>  <p style="text-align: center;">Ø 40.00</p>	<p>SEC NO. :-LIV-2013      W.T:- 0.468 kg/MTR</p>  <p style="text-align: center;">Ø39.45</p>
<p>SEC NO. :-LIV-2015      W.T:- 0.458 kg/MTR</p>  <p style="text-align: center;">Ø39,8</p>	<p>SEC NO. :-LIV-2005      W.T:- 0.312 kg/MTR</p>  <p style="text-align: center;">Ø39.25</p>
<p>SEC NO. :-LIV-2001      W.T:- 0.560 kg/MTR</p>  <p style="text-align: center;">Ø39.86</p>	<p>SEC NO. :-LIV-2006      W.T:- 0.346 kg/MTR</p>  <p style="text-align: center;">Ø38.00</p>

# VENETIAN BLINDS

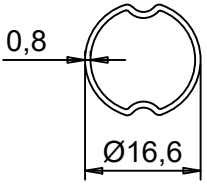
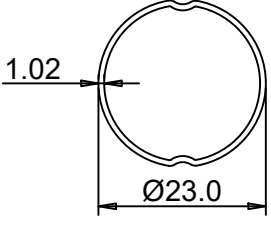
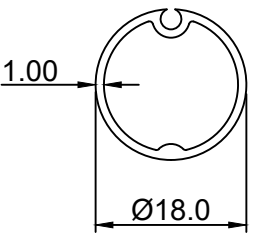
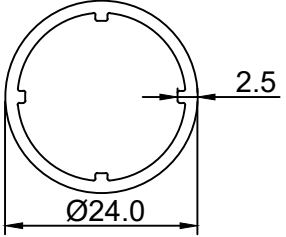
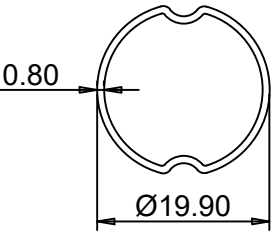
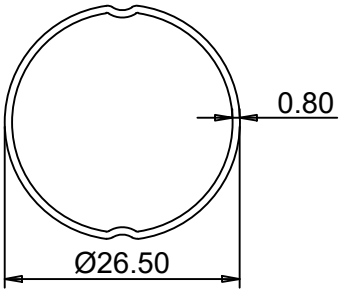
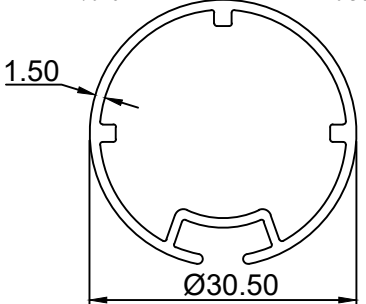
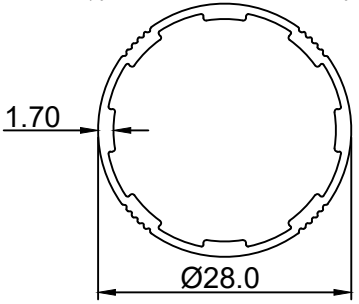
<p>SEC NO. :-6114                      W.T:- 0.406 kg/MTR</p>  <p style="text-align: center;">Ø16,6</p>	<p>SEC NO. :-6113                      W.T:- 0.558 kg/MTR</p>  <p style="text-align: center;">Ø23.0</p>
<p>SEC NO. :-6066                      W.T:- 0.160 kg/MTR</p>  <p style="text-align: center;">Ø18.0</p>	<p>SEC NO. :-LIV-2010                      W.T:- 0.302 kg/MTR</p>  <p style="text-align: center;">Ø24.0</p>
<p>SEC NO. :-6113                      W.T:- 0.490 kg/MTR</p>  <p style="text-align: center;">Ø19.90</p>	<p>SEC NO. :-6111                      W.T:- 0.644 kg/MTR</p>  <p style="text-align: center;">Ø26.50</p>
<p>SEC NO. :-7016                      W.T:- 0.360 kg/MTR</p>  <p style="text-align: center;">Ø30.50</p>	<p>SEC NO. :-7011                      W.T:- 0.280 kg/MTR</p>  <p style="text-align: center;">Ø28.0</p>

# VENETIAN BLINDS

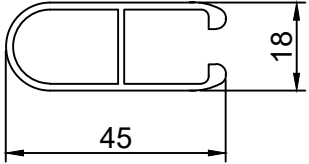
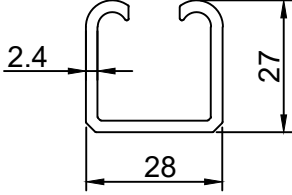
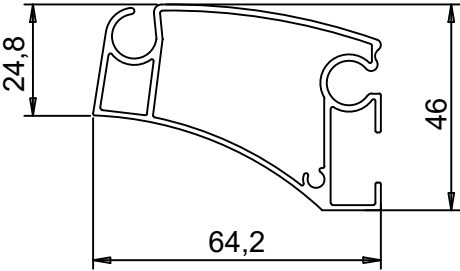
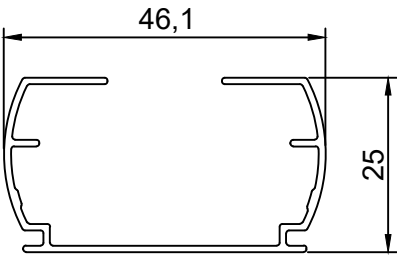
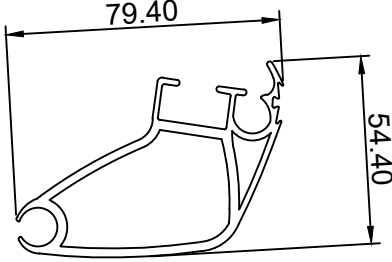
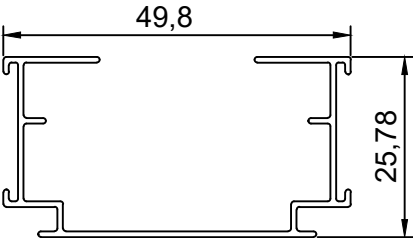
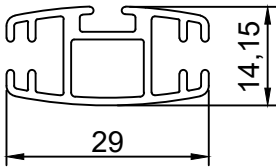
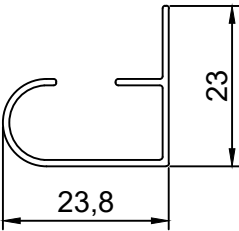
<p>SEC NO. :-9321                      W.T:- 0.470 kg/MTR</p> 	<p>SEC NO. :-6006                      W.T:- 0.560 kg/MTR</p> 
<p>SEC NO. :-9312                      W.T:- 0.960 kg/MTR</p> 	<p>SEC NO. :-VS-8105                      W.T:- 0.340 kg/MTR</p> 
<p>SEC NO. :-9311                      W.T:- 0.900 kg/MTR</p> 	<p>SEC NO. :-VS-8110                      W.T:- 0.345 kg/MTR</p> 
<p>SEC NO. :-7012                      W.T:- 0.340 kg/MTR</p> 	<p>SEC NO. :-VS-8140                      W.T:- 0.740 kg/MTR</p> 

# VENETIAN BLINDS

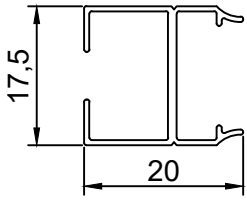
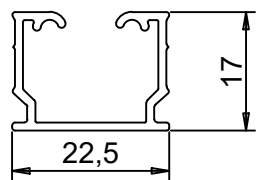
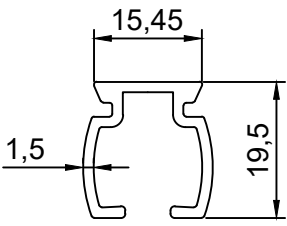
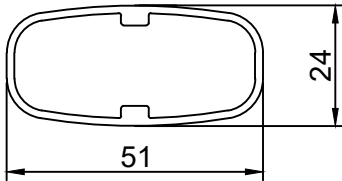
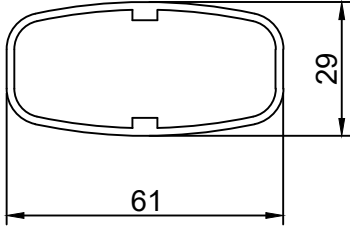
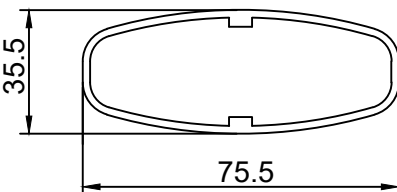
<p>SEC NO. :-VS-8142      W.T:- 0.130 kg/MTR</p> 	<p>SEC NO. :-VS-8135      W.T:- 0.210 kg/MTR</p> 
<p>SEC NO. :-VS-8145      W.T:- 0.280 kg/MTR</p> 	<p>SEC NO. :-9301      W.T:- 0.740 kg/MTR</p> 
<p>SEC NO. :-9302      W.T:- 0.880 kg/MTR</p> 	<p>SEC NO. :-9303      W.T:- 1.010 kg/MTR</p> 
<p>SEC NO. :-9310      W.T:- 1.080 kg/MTR</p> 